



Model Number

CSM58

Features

- Industrial standard housing Ø58 mm
- Recessed hollow shaft
- 30 Bit multiturn
- Galvanically isolated CAN interface
- 2 limit switches
- 8 programmable cams
- Velocity and acceleration output
- Event triggered process data transfer

Description

Absolute encoders deliver an absolute step value for each angle setting. All these values are represented by code samples on one or more code disks which are sampled by a photoelectric array. The absolute encoder has a maximum basic resolution of 65536 steps per revolution (16 Bits). In the multiturn design, additional up to 16384 revolutions (14 Bits) can be resolved. This results in a total maximum resolution of 1073741824 steps (30 Bits).

The encoders integrated CAN bus interface supports all CANopen functions. The following operating modes can be programmed, and can be selectively turned on or off:

- Polled mode
- Cyclic mode
- Sync mode

The absolute encoder is mounted directly onto the application shaft, without any coupling. Rotation of the encoder is prevented by a torque rest. The bus electronics module is integrated into the removable housing cover. This makes it possible to mount or replace the encoder and the bus electronics separately during installation or service.

Technical data

General specifications

Detection type	photoelectric sampling
Device type	Multiturn absolute encoder

Functional safety related parameters

MTTF _d	70 a
Mission Time (T _M)	20 a
L ₁₀	1.9 E+11 at 6000 rpm and 20/40 N axial/radial shaft load
Diagnostic Coverage (DC)	0 %

Electrical specifications

Operating voltage U _B	10 ... 30 V DC
No-load supply current I ₀	max. 230 mA at 10 V DC max. 100 mA at 24 V DC
Time delay before availability t _v	< 250 ms
Linearity	± 2 LSB at 16 Bit, ± 1 LSB at 13 Bit, ± 0,5 LSB at 12 Bit
Output code	binary code
Code course (counting direction)	cw ascending (clockwise rotation, code course ascending) cw descending (clockwise rotation, code course descending)

Interface

Interface type	CANopen
Resolution	
Single turn	up to 16 Bit
Multiturn	14 Bit
Overall resolution	up to 30 Bit
Transfer rate	max. 1 MBit/s
Standard conformity	communication profile: DS 301 Device profiles: DS 406 and DS 417, programmable according to class 2

Connection

Terminal compartment	in removable housing cover
----------------------	----------------------------

Standard conformity

Degree of protection	DIN EN 60529, IP65 IP66 (with shaft seal)
Climatic testing	DIN EN 60068-2-30, no moisture condensation
Emitted interference	EN 61000-6-4:2007
Noise immunity	EN 61000-6-2:2005
Shock resistance	DIN EN 60068-2-27, 100 g, 6 ms
Vibration resistance	DIN EN 60068-2-6, 20 g, 10 ... 2000 Hz

Ambient conditions

Operating temperature	-40 ... 85 °C (-40 ... 185 °F)
Storage temperature	-40 ... 85 °C (-40 ... 185 °F)

Mechanical specifications

Material	
Combination 1	housing: powder coated aluminum flange: aluminum shaft: stainless steel
Combination 2 (Inox)	housing: stainless steel flange: stainless steel shaft: stainless steel
Mass	approx. 600 g (combination 1) approx. 1200 g (combination 2)
Rotational speed	max. 12000 min ⁻¹
Moment of inertia	30 gcm ²
Starting torque	≤ 3 Ncm (version without shaft seal)
Tightening torque, fastening screws	max. 1.8 Nm
Shaft load	
Angle offset	± 0.9 °
Axial offset	static: ± 0.3 mm, dynamic: ± 0.1 mm
Radial offset	static: ± 0.5 mm, dynamic: ± 0.2 mm

Approvals and certificates

UL approval	cULus Listed, General Purpose, Class 2 Power Source
-------------	---

Dimensions

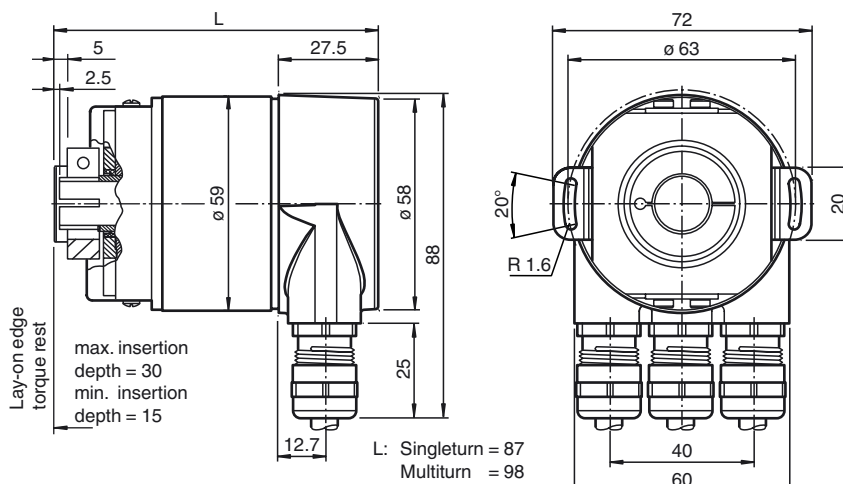

Electrical connection

Terminal	Cable	Explanation
⊥	-	Ground connection for power supply
(+)	Red	Power supply
(-)	Black	Power supply
G	-	CAN ground
L	Blue	CAN low
H	White	CAN high
G	-	CAN ground
L	Blue	CAN low
H	White	CAN high

Indicating and operating elements

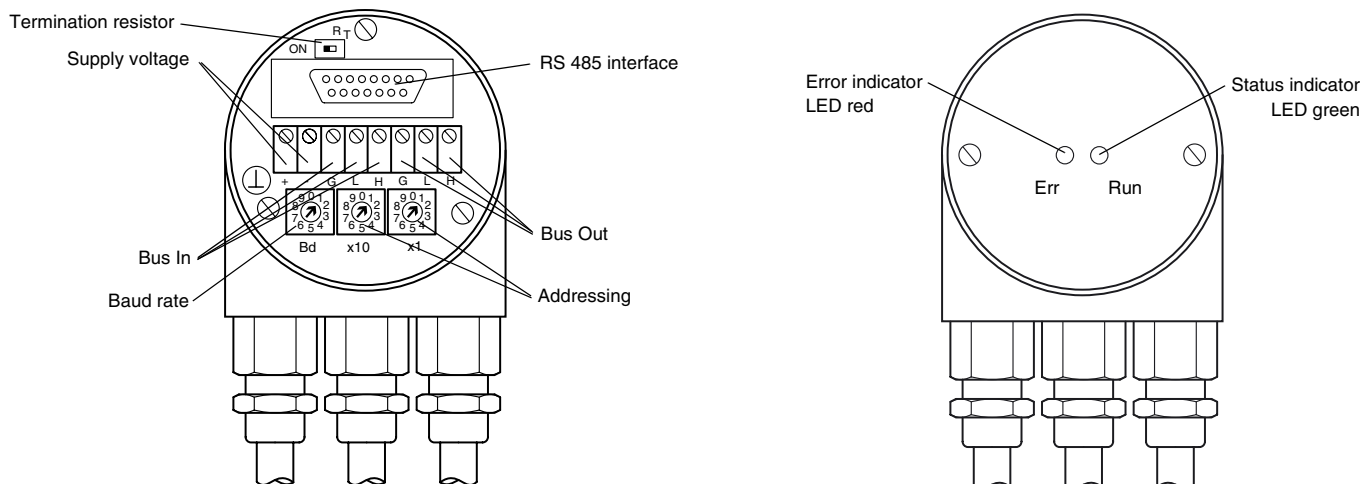

Adjusting the participant address

The participant address can be adjusted with the rotary switches. The address can be defined between 1 and 96, and may only be assigned once. The addresses 97 ... 99 are reserved.

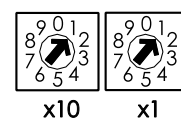

Adjusting the termination resistor

The terminating resistor R_T (121 Ω) can be connected to the circuit by means of the switch:



Baud rate adjustment

Baud rate [kBit/s]	Switch position	Baud rate [kBit/s]	Switch position
20	0	500	5
50	1	800	6
100	2	1000	7
125	3	reserved	8
250	4	set baud rate by SDO message and LSS	9

LED-indicators

CAN Run (green)	State	Description
flickering	AutoBirate / LSS	Auto-birate detection is in progress or LSS services are in progress
blinking	PREOPERATIONAL	Encoder is in state PREOPERATIONAL
single flash	STOPPED	Encoder is in state STOPPED
double flash		reserved
triple flash	Program / Firmware download	a software download is running on the encoder
on	OPERATIONAL	the encoder is in state OPERATIONAL
Err (red)	State	Description
off	no error	the encoder is in working condition
flickering	AutoBirate / LSS	Auto-birate detection is in progress or LSS services are in progress
blinking	invalid configuration	general configuration error
single flash	Warning limit reached	at least one of the error counters of the CAN controller has reached or exceeded the warning level (too many error frames)
double flash	Error control event	a guard event (NMT-slave or NMT-master) or a heartbeat event (heartbeat consumer) has occurred
triple flash	Sync. error	the sync. message has not been received within the configured communication cycle period time out (see objekt 1006h)
quadruple flash	Error, event-timer	an expected PDO has not been received before the even-timer elapsed
on	Bus off	the CAN controller is bus off

Release date: 2018-07-27 09:21 Date of issue: 2018-07-27 149163_eng.xml

Programmable CAN operating modes

Mode	Explanation
Polled mode	The connected host requests the current actual position value via a remote transmission request telegram. The absolute encoder reads in the current position, calculates all parameters that have been set and sends back the process actual value through the same CAN identifier.
Cyclic mode	The absolute encoder sends the current actual process value cyclically, without being prompted by the host. The cycle time can be programmed in milliseconds for values between 1 ms and 65536 ms.
Sync mode	After the sync telegram has been received by the host, the absolute encoder sends the current actual process value. If multiple nodes should respond to the sync telegram, the individual nodes report one after the other according to their CAN identifier. There is no programming of an offset time. The sync counter can be programmed so that the rotary encoder does not transmit until after a defined number of sync telegrams.

Programmable rotary encoder parameters

Parameter	Explanation
Operating parameter	The direction of rotation (complement) can be specified by parameter as the operating parameter. This parameter determines the direction of rotation in which the output code will ascend or descend.
Resolution per revolution	The "Resolution" parameter is used to program the rotary encoder so that a desired number of steps can be implemented in reference to one revolution.
Overall resolution	This parameter indicates the desired number of measurement units of the entire travel length. This value must not exceed the overall resolution of the absolute encoder.
Preset value	The preset value is the desired position value that must be achieved for a specific physical setting of the axis. The preset value parameter is used to set the actual position value to the desired actual process value.
2 limit switches	A total of two positions can be programmed. The absolute encoder sets one bit to high state in the 32 Bit actual process value if a value falls outside the range between these two positions.
8 cam switches	Up to 8 position values can be programmed as cams. By reaching these values bits in object 6300h Cam state register are set.

Order code



- Number of bits singleturn**
 - 12 4096 (standard)
 - 13 8192
 - 16 65536
- Number of bits multiturn**
 - 12 4096 (standard)
 - 14 16384
- Option 2**
 - N Not expanded
- Output code**
 - B Binary
- Option 1**
 - 0 No option
- Exit position**
 - R Radial
- Connection type**
 - AG Removable housing cover with terminal compartment
 - AN Removable housing cover with connectors M12x1
- Shaft dimension/flange version**
 - F1A Recessed hollow shaft Ø10 mm x 30 mm
 - F2A Recessed hollow shaft Ø12 mm x 30 mm
 - F3A Recessed hollow shaft Ø15 mm x 30 mm
- Housing material**
 - N Aluminium, powder coated
 - I Inox
 - W Aluminium, powder coated with shaft seal
- Principle of operation**
 - M Multiturn
- Shaft version**
 - S Recessed hollow shaft
- Data format**
 - C CAN-Bus

Release date: 2018-07-27 09:21 Date of issue: 2018-07-27 149163_eng.xml